

EcoMix Shower Mixer with Diverter



PRODUCT CODE

VECM035

COLOUR/FINISHES

Chrome

PRESSURE TYPE

Mains Pressure only

MAXIMUM PRESSURE

500kPa (As per NZ Building Code AS/NZ 3500.1)

MINIMUM PRESSURE

150kPa

CARTRIDGE/HEADWORKS

HiFlo Cartridge

MAXIMUM TEMPERATURE

65°C

PLUMBING CONNECTION

15mm

CERTIFICATION

WaterMark Certified

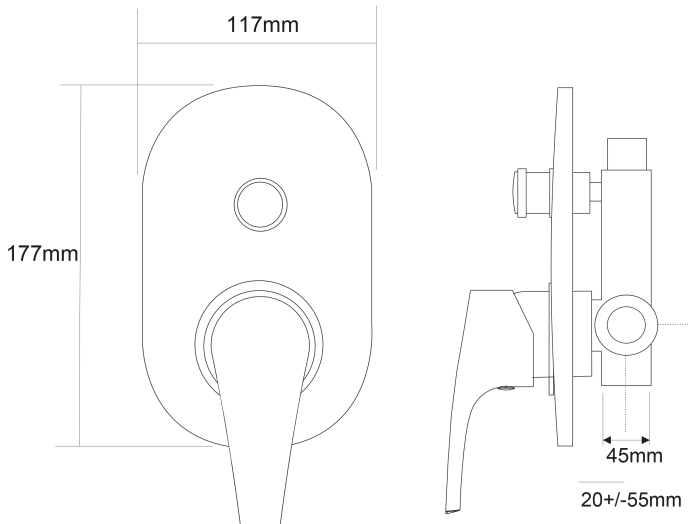

Voda Plumbingware products are in full compliance with the requirements as set out in the New Zealand Building Code:

www.vodaplumbingware.co.nz/building-code-clauses/

This product is not subject to a warning or ban under section 26 of the Building Act 2004.

Specifications and dimensions correct at time of publication however are subject to change without notice.

Please refer to physical product prior to installation.

Installation instructions for this product are available from the product page on vodaplumbingware.co.nz